

# Wood Stone



Gas oven shown with optional stainless steel mantle.

## MT. ADAMS 5'

Stone Hearth Oven



**Job Name**

**Model**

WS-MS-5

**Item#**

### Hearth Capacity

8" pizzas	12-16
10" pizzas	10-12
12" pizzas	8
16" pizzas	5

Assuming 5-minute cook times, the approximate maximum hourly production capacity can be calculated by multiplying the above numbers by 12.

### OPTIONAL ACCESSORIES

- Doorway and Service Panel Extensions
- Stainless Steel or Black Granite Mantles
- Stainless Steel Oven Tools
- Custom Finishes
- Exhaust Fan
- Exhaust Hood
- Wood Burning Option
- Custom Wood Burning Accessories
- Multiple Opening Option

The Mt. Adams series oven features a standard door opening 30-inches wide x 10-inches high. The inside diameter of the oven floor is 52-inches, resulting in a 15-square-foot cooking hearth surface.

Whether heated by gas, wood or a combination of the two fuels, the dense, high-temperature ceramic formulation of which the hearth and dome are cast creates a "deep heat sink" within the chamber of the oven. The 1,100-pound, monolithic, 4-inch thick cast-ceramic floor sits on 4-inches of rigid insulation. The 1,100-pound, monolithic dome is also cast to a thickness of at least 4-inches. The hearth and dome are connected and supported by a carefully tensioned steel exoskeleton, which ensures structural integrity and long life. The body of the oven rests on a 10-gauge steel pan bolted to a heavy-duty, 3-inch angle iron stand. The oven is wrapped with at least 2-inches of spun ceramic fiber insulation and enclosed (top and sides) with 16-gauge galvanized steel. The oven arrives completely assembled and ready to set in place.

**GAS-FIRED** The oven can be manufactured to burn either propane or natural gas; this must be specified at the time of order.

**THE RADIANT FLAME** The gas oven is heated by an easily adjustable wall of radiant flame (105,000-BTU max.) located at the rear of the cooking chamber. User control of this ample heat input ensures the ability to balance the oven's radiated top heat with that being conducted and radiated from the floor.

**THE UNDERFLOOR IR BURNER** An 83,000-BTU thermostatically controlled infrared burner can be mounted under the 4-inch thick, monolithic oven deck to ensure high production capacity with no heat recovery issues.

The combined effect of these two heat sources makes the Mt. Adams an extremely powerful and responsive stone hearth oven. The oven can be equipped with either or both burners. *If only the underfloor IR burner is present, the oven must be fueled primarily with wood burning in the chamber.* **Limited wood burning** is an option for ovens with all gas burner configurations, but *must be specified at time of order to ensure proper labeling.* All Mt. Adams Gas-Fired and Wood w/ Gas Assist ovens are ETL Listed.

**WOOD-FIRED** The Mt. Adams is also available simply as a Wood-Fired oven. A hardwood fire in the chamber of the oven is all that is needed to keep the massive ceramic interior charged with heat, even in the face of very high levels of food production.

**ALL MODELS** The combustion products of the Gas and/or Wood used to fuel the oven vent through a 10-inch O.D. flue collar located above the doorway. The Mt. Adams can be direct connected to a power-ventilated, grease-rated chimney or can be vented using a Listed Type 1 exhaust hood, or one constructed in accordance with NFPA 96 and all relevant local and national codes. The oven must be vented in accordance with all relevant local and national codes, and in a manner acceptable to the authority having jurisdiction. Models that utilize wood as a fuel source must be vented as a solid fuel appliance.



An ongoing program of product improvement may require us to change specifications without notice.  
Revised June 2008

### WOOD STONE CORPORATION

1801 W. Bakerview Rd.  
Bellingham, WA 98226 USA

Toll Free (800) 988-8103

Tel (360) 650-1111

Fax (360) 650-1166

[info@woodstone-corp.com](mailto:info@woodstone-corp.com) or visit [www.woodstone-corp.com](http://www.woodstone-corp.com)



# MT. ADAMS 5'

Stone Hearth Oven

# Model WS-MS-5

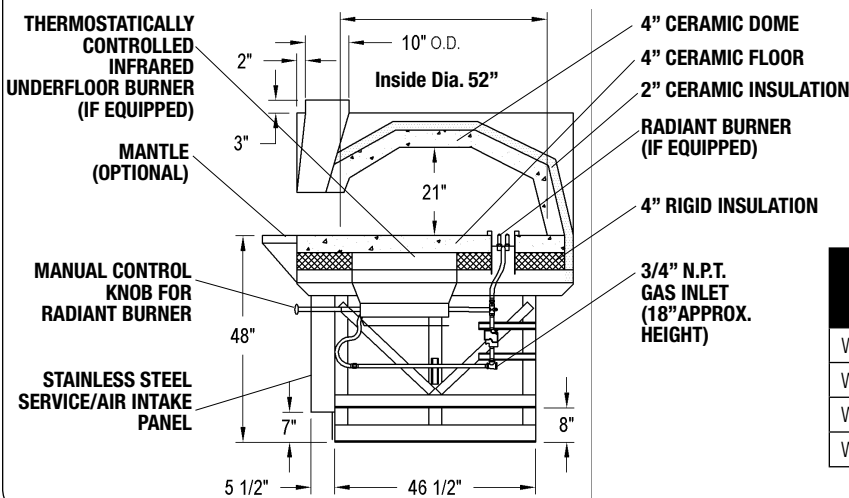
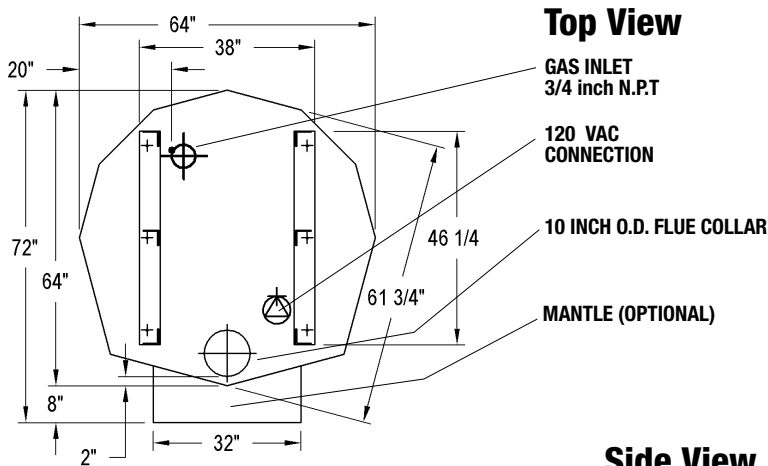
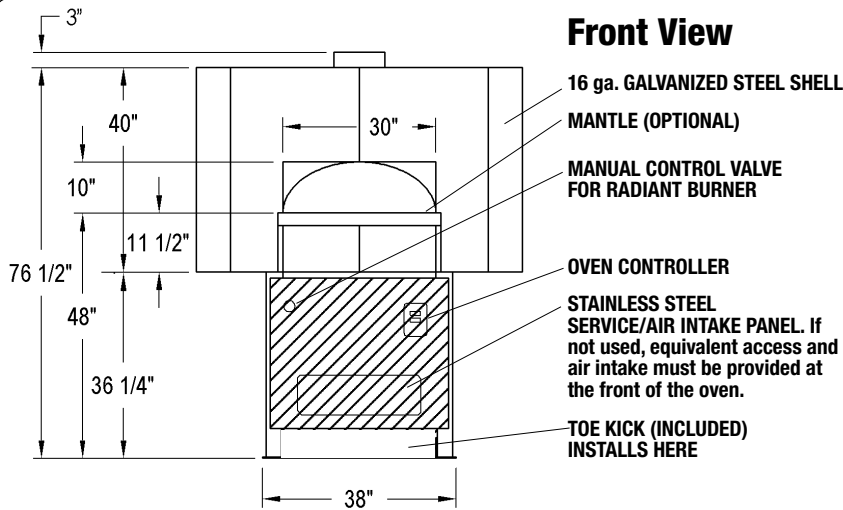

### UTILITIES REQUIRED

#### Gas and Wood Gas Combination Ovens

1. 120-VAC/ 1.1-AMP Electrical Supply
2. 188,000-BTU Natural Gas Supply OR 159,000-BTU Propane (LP) Supply

#### Wood-fired Only

1. 120-VAC/ 1.1-AMP Electrical Supply.

### FACADE INFORMATION

1. All facades or enclosures are by others; all ovens require 1-inch side clearance, and 14-inches top clearance to combustible construction. Any construction above, and 6 inches to either side of the oven doorway, must be non-combustible.
2. Any facade or enclosure below the mantle of Gas-Fired and Wood w/ Gas Assist ovens must allow the following:

- a) Unobstructed access 17-inches to each side of centerline for removal of service / intake panel.
- b) Easy access to all controls.
- c) Sufficient combustion air for gasburners; see installation information for details.

### VENTING INFORMATION

The Mt. Adams can be direct connected to a power-ventilated, grease-rated chimney or can be vented using a Listed Type 1 exhaust hood, or one constructed in accordance with NFPA 96 and all relevant local and national codes. The oven must be vented in accordance with all relevant local and national codes, and in a manner acceptable to the authority having jurisdiction. Models that utilize wood as a fuel source must be vented as a solid fuel appliance.

**Unit Shipping Weight:  
3,600 lbs.**

Model Number	Underfloor IR	Radiant Flame	Wood Optional	Wood Required	Gas Type
WS-MS-5-RFG-IR	X	X	-W		LP or NG
WS-MS-5-RFG		X	-W		LP or NG
WS-MS-5-W-IR	X			X	LP or NG
WS-MS-5-W				X	No GAS



An ongoing program of product improvement may require us to change specifications without notice.  
 Revised June 2008

**WOOD STONE CORPORATION**  
 1801 W. Bakerview Rd.  
 Bellingham, WA 98226 USA

Toll Free (800) 988-8103  
 Tel (360) 650-1111  
 Fax (360) 650-1166

info@woodstone-corp.com or visit www.woodstone-corp.com