

Wood Stone



Oven shown with optional stainless steel mantle.

Hearth Capacity

8" pizzas	8-10
10" pizzas	5-6
12" pizzas	4
16" pizzas	1-2

Assuming 5-minute cook times, the approximate maximum hourly production capacity can be calculated by multiplying the above numbers by 12.

Note: Highlighted capacities are considered an operational challenge.

OPTIONAL ACCESSORIES

- Doorway and Service Panel Extensions
- Stainless Steel or Black Granite Mantles
- Stainless Steel Oven Tools
- Custom Finishes
- Exhaust Fan
- Exhaust Hood
- Wood Burning Option
- Custom Wood Burning Accessories

MT. CHUCKANUT 4'

Stone Hearth Oven



Job Name	
Model	WS-MS-4-RFG-IR
Item#	
Fuel Type	Dual Burner, Gas-Fired

The Mt. Chuckanut Dual Burner, Gas-Fired oven features a standard door opening 20 inches wide x 10 inches high. The inside diameter of the oven floor is 37 inches, resulting in a 9-square-foot cooking surface. The oven is approved for installation with a 1-inch side clearance to combustible building materials.

The dense, high-temperature ceramic formulation of which the hearth and dome are cast creates a "deep heat sink" within the chamber of the oven. The oven is primarily heated by an easily adjustable (68,000-BTU max.) wall of radiant flame located at the rear of the cooking chamber. A 47,000-BTU, thermostatically controlled infrared burner mounted under the floor ensures constant deck temperatures. The combined effect of these heat sources makes the Mt. Chuckanut a very powerful and responsive stone hearth oven.

The 650-pound, monolithic, 4-inch thick, cast-ceramic floor sits on 4 inches of rigid insulation. The 700-pound, monolithic dome is cast to a thickness of at least 4 inches. The hearth and dome are connected by a carefully tensioned steel exoskeleton which ensures structural integrity and long life. The body of the oven rests on a 12-gauge steel pan bolted to a heavy-duty, 3-inch angle iron stand. The oven is wrapped with at least 2 inches of spun ceramic fiber insulation and enclosed (top and sides) with 16-gauge galvanized steel. The oven arrives completely assembled and ready to set in place.

The oven can be manufactured to burn either propane or natural gas; this must be specified at the time of order.

The oven vents through an 8-inch O.D. flue collar located above the doorway. The Mt. Chuckanut can be direct connected to a power-ventilated, grease-rated chimney or can be vented using a Listed Type 1 exhaust hood or one constructed in accordance with NFPA 96 and all relevant local and national codes. The oven must be vented in accordance with all relevant local and national codes, and in a manner acceptable to the authority having jurisdiction.



An ongoing program of product improvement may require us to change specifications without notice.
Revised July 2010

WOOD STONE CORPORATION
1801 W. Bakerview Rd.
Bellingham, WA 98226 USA

Toll Free (800) 988-8103
Tel (360) 650-1111
Fax (360) 650-1166

info@woodstone-corp.com or visit www.woodstone-corp.com





MT. CHUCKANUT 4'

Stone Hearth Oven

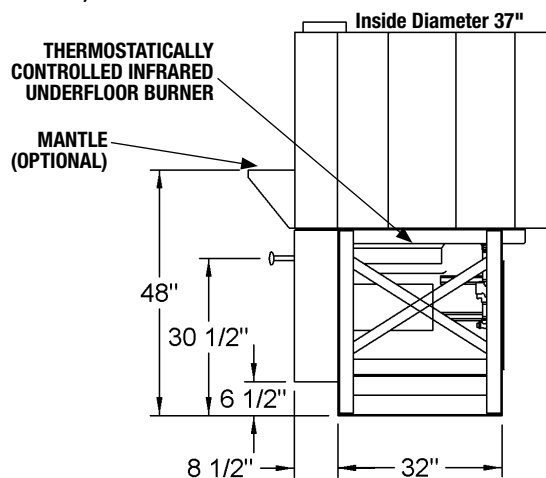
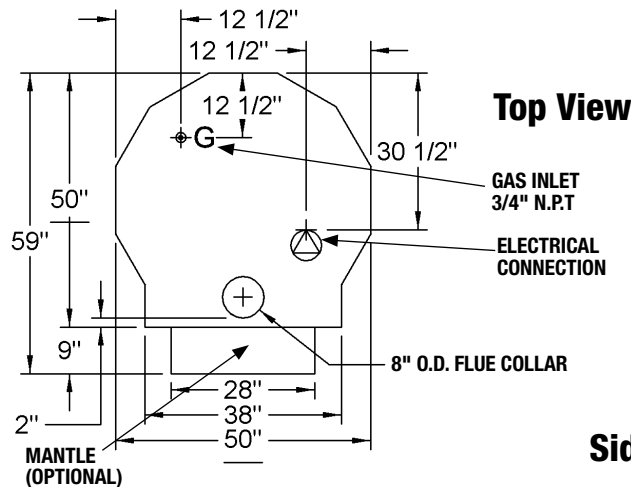
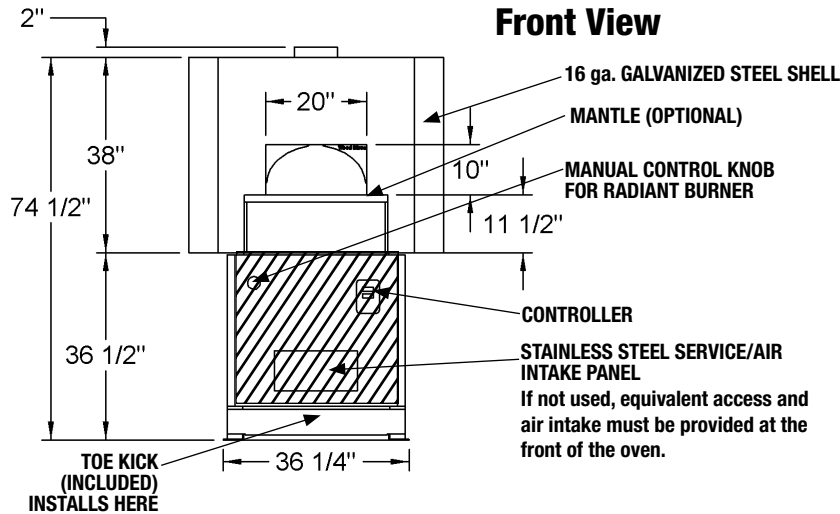
Model
WS-MS-4-RFG-IR



UTILITIES REQUIRED

1. 120-VAC/ 1.1-AMP Electrical Supply- 
Connection made beneath oven as shown.
2. 115,000-BTU Natural Gas Supply OR 
102,000-BTU Propane (LP) Supply

FACADE INFORMATION

1. All facades or enclosures are by others; see installation information for details.
2. Any facade or enclosure below the mantle must allow the following:

- a) Unobstructed access 16 inches to each side of centerline for removal of service / intake panel.
- b) Easy access to all controls.
- c) Sufficient combustion air for gas burner; see installation information for details.

VENTING INFORMATION

The Mt. Chuckanut can be direct connected to a power-ventilated, grease-rated chimney or can be vented using a Listed Type 1 exhaust hood or one constructed in accordance with NFPA 96 and all relevant local and national codes. The oven must be vented in accordance with all relevant local and national codes, and in a manner acceptable to the authority having jurisdiction.

**Unit Shipping Weight:
2,400 lbs.**



WoodStone

An ongoing program of product improvement may require us to change specifications without notice.
Revised July 2010

WOOD STONE CORPORATION
1801 W. Bakerview Rd.
Bellingham, WA 98226 USA

Toll Free (800) 988-8103
Tel (360) 650-1111
Fax (360) 650-1166

info@woodstone-corp.com or visit www.woodstone-corp.com