



Job Name	
Model	WS-GVR-10
Item#	
Fuel Type	Gas-Fired

OPTIONAL ACCESSORIES

- Rear Access Door
- Countertop Configuration
- Additional Skewers, Bird Bells and Hooks

The unique design of the Whatcom Rotisserie allows different foods to be cooked at the same time, in the same rotisserie, without exchanging flavors (cross contamination). The unit has 10 spit locations (stations), allowing an enormous variety of products to be cooked simultaneously.

The unit comes standard with a tempered glass front door, so that the cooking process is fully visible to chefs and customers alike. Although the front-loading model is standard, the Whatcom is available with an optional rear access glass door, so that it can be loaded from either side. The rotisserie features a constant drip water bath, so that grease from the cooking products is constantly being removed from the cabinet. The water bath is equipped with a removable stand pipe for ease of cleaning.

The cabinet of the Whatcom Rotisserie is constructed of 16-gauge polished 304 stainless steel (#4 finish). The standard unit is on legs equipped with heavy-duty, non-marking casters, however, the Whatcom can be ordered as a counter-top model.

The Whatcom is powered by three gas burners: two programmable IR burners (in the front corners of the cabinet), and a showy and powerful radiant flame post, located in the center of the unit. The IR burners operate on a ten minute cycle, and can be programmed to burn for any percentage of that cycle. They can also be turned off completely so that the rotisserie is powered by the center flame post alone. The drum of the rotisserie turns at a speed of 1.5 revolutions per minute. Each spit connection (or station) rotates approximately 6.5 times during every revolution of the drum.

The unit comes standard with a variety of spits: 9 bird bells, 5 small item skewers, and 5 three-prong rib/meat hooks. A maximum of 3 bird bells can be hung from one station, but birds can not be cooked at adjacent stations; this gives the Whatcom a maximum capacity of 15 birds.

The Whatcom Vertical Rotisserie should be installed in accordance with all relevant national and local codes, and in a manner acceptable to the authority having jurisdiction.



An ongoing program of product improvement may require us to change specifications without notice.
Revised November 2008

WOOD STONE CORPORATION
1801 W. Bakerview Rd.
Bellingham, WA 98226 USA

Toll Free (800) 988-8103
Tel (360) 650-1111
Fax (360) 650-1166

info@woodstone-corp.com or visit www.woodstone-corp.com



WHATCOM
Gas Vertical Rotisserie

Model
WS-GVR-10

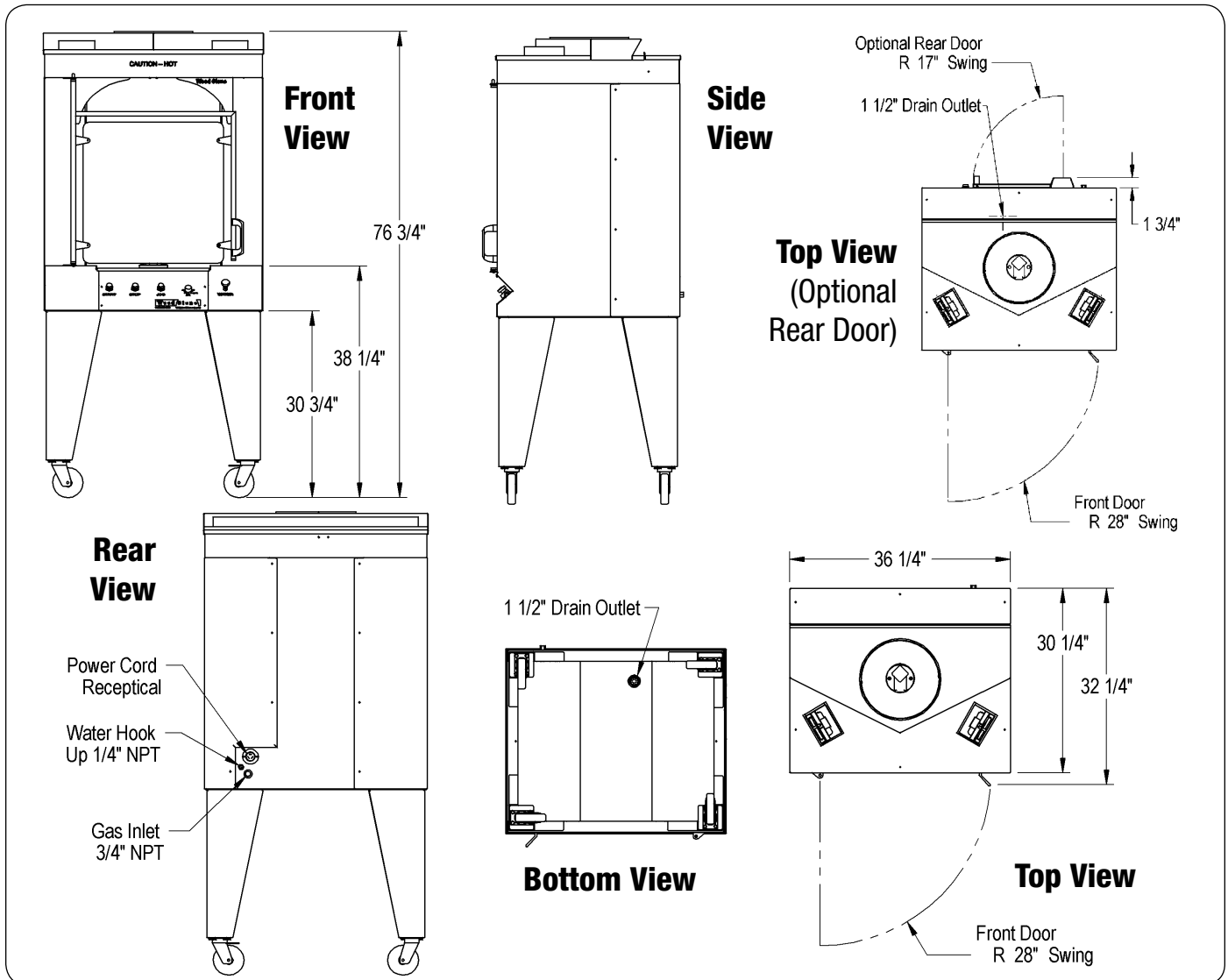

UTILITY SPECIFICATIONS

Note: This unit is on casters; utility hookups should be made in such a way as to allow mobility of the rotisserie for service and maintenance purposes. We recommend "quick disconnects" and flexible utility connections.

Electrical Provide 120 VAC, 15 Amp outlet (appliance is 1.3 Amp rated). Note: a grounded cord and plug (three prong) is provided by Wood Stone for a standard 120 outlet.

Water Provide incoming water supply equipped with a 1/4" N.P.T. (male) fitting.

Drain Provide connection to floor sink (grease trap) equipped with a 1 1/2" slip-fit (male) fitting.

Gas Rotisserie-Provide 175,000 BTU Natural Gas or 185,000 BTU Propane (LP) input. Rotisserie gas inlet is a 3/4" N.P.T. (female) fitting. The maximum inlet pressure is 0.5 PSI.

Unit Shipping Weight: 750 lbs.



An ongoing program of product improvement may require us to change specifications without notice.
Revised November 2008

WOOD STONE CORPORATION
1801 W. Bakerview Rd.
Bellingham, WA 98226 USA

Toll Free (800) 988-8103
Tel (360) 650-1111
Fax (360) 650-1166

info@woodstone-corp.com or visit www.woodstone-corp.com