

<b>Job Name</b>	
<b>Model</b>	WS-TL-AD
<b>Item#</b>	

### DOUBLE COMPARTMENT ASH DOLLY

The Wood Stone Double Compartment Ash Dolly is an efficient and safe means to store and transport the ash that needs to be removed from the oven each morning. It has two compartment sleeves for ash storage. After the first sleeve has been filled, the second sleeve should be filled. By the time the second sleeve has been filled, the first will have had time to cool and should be safe to dump. By separation of the ash into two compartments, it is easier to control the disposal of leftover ash in a safe manner.

Caution is necessary to prevent any live coals mixed in with the ash from being dumped into an area or container with combustibles. **ALL ASH AND COALS SHOULD BE DOUSED WITH WATER AND EXTINGUISHED BEFORE FINAL DISPOSAL.**

The unit comes with a lock eye, and a brass security lock with two keys. The unit is made of 16-gauge stainless steel with a non-marking perimeter bumper edge. It has four non-marking, fully revolving low profile casters.

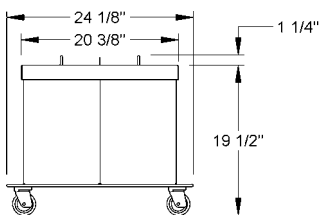
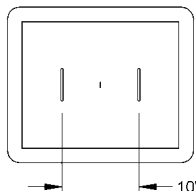

**Unit Weight: 75 lbs.  
Minimum Shipping Weight: 140 lbs.**

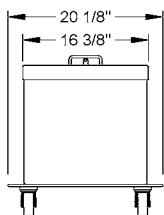

## ASH DOLLY AND WOOD CART



<b>Job Name</b>	
<b>Model</b>	WS-TL-WHC
<b>Item#</b>	

### WOOD HANDLING ACCESSORIES

Wood Stone's stainless steel wood handling cart is designed to address the day-to-day issues of getting fuel from the main wood storage area to the solid fuel appliance. The 6.5-cubic-foot capacity cart is constructed from 14-gauge stainless steel. The cart is designed to hold 18 inch logs and to contain the accompanying bark chips and sawdust. It rolls easily over thresholds and carpeting on durable, 3 inch x 7/8 inch, fully revolving, non-marking casters. This piece is built for a lifetime of reliable use.



**Unit Weight: 70 lbs.  
Minimum Shipping Weight: 150 lbs.**

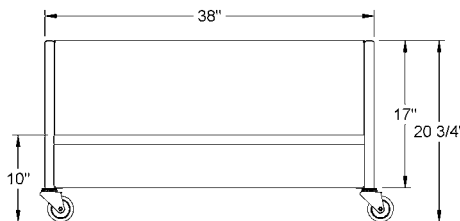
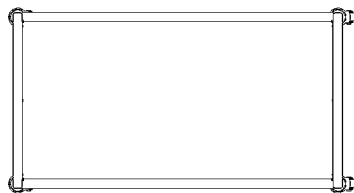
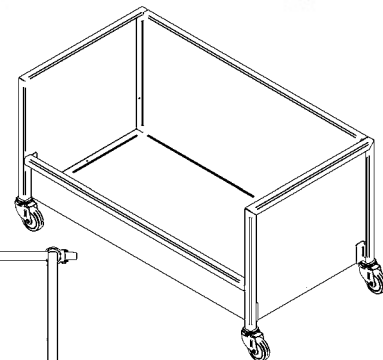

An ongoing program of product improvement may require us to change specifications without notice.  
Revised March 2010

**WOOD STONE CORPORATION**  
1801 W. Bakerview Rd.  
Bellingham, WA 98226 USA

Toll Free (800) 988-8103  
Tel (360) 650-1111  
Fax (360) 650-1166

[info@woodstone-corp.com](mailto:info@woodstone-corp.com) or visit [www.woodstone-corp.com](http://www.woodstone-corp.com)