

CHARCOAL BROILER OVEN

Josper by Wood Stone Charcoal Broiler Oven



Job Name	
Model	WS-CBO-3728
Item#	
Fuel Type	Charcoal-Fired

BROILER OVEN CAPACITY:

The Broiler Oven comes standard with (2) 21.5-inch x 30-inch cooking grates, resulting in 645 square inches of cooking area for each grate. The upper grate is typically used for slower cooking items like roasted vegetables, fish and larger roasted meats. The lower grate is used for items requiring extremely intense heat - like steaks and seafood items.

OPTIONAL ACCESSORIES

- Tray Support Models Available
- Custom Door and Cabinet Finishes
- Dual Compartment Ash Dolly

The Josper by Wood Stone Charcoal Broiler Oven provides an elegant solid fuel charcoal broiler solution in an oven package. Introduced over 40 years ago in Spain and now found in over 9,000 restaurants across Europe this dynamic piece of cooking equipment defies simple categorization. Loved equally by steakhouses, artisan bistros, tapas cafes and the culinary elite it finds home in the serious kitchen.

The unit comes with two adjustable broiler racks that allow the chef to cook a wide variety of meats and vegetables in the oven simultaneously which makes this versatile piece of equipment capable of very high production.

By combining the features of an enclosed oven with the traditional characteristics of charbroiled cooking, this piece offers efficiency in utilizing the heat produced by the charcoal. The dual damper system helps minimize charcoal consumption while allowing the unit to maintain high cooking temperatures for extended periods of time, and helps to greatly influence and enhance the flavor profile of the foods being cooked.

The oven sits on a heavy-duty stainless steel cabinet that incorporates an easily removable ash collection system. The unit also ships with an oven-mounted firebreak, a poker, brush and grill tongs. Other accessories are available.

The Broiler/Oven is ETL Listed with an 18-inch side and 6-inch back clearance to combustible construction.

The Josper by Wood Stone Charcoal Broiler Ovens must be vented with a Listed Type 1 exhaust hood or one constructed in accordance with all relevant local and national codes. The oven must be vented as a solid fuel appliance, and in accordance with all relevant local and national codes, and in a manner acceptable to the authority having jurisdiction. See installation manual for additional information.



Intertek



Intertek
ANSI/NSF STD 4

Wood Stone

An ongoing program of product improvement may require us to change specifications without notice.
Revised October 2011

WOOD STONE CORPORATION

1801 W. Bakerview Rd.
Bellingham, WA 98226 USA

Toll Free (800) 988-8103

Tel (360) 650-1111

Fax (360) 650-1166

info@woodstone-corp.com or visit woodstone-corp.com



CHARCOAL BROILER OVEN

Josper by Wood Stone Charcoal Broiler Oven

Model
WS-CBO-3728

Front View

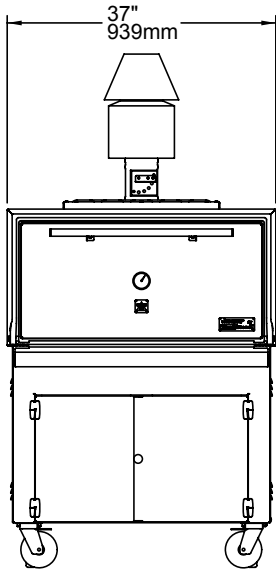

Side View

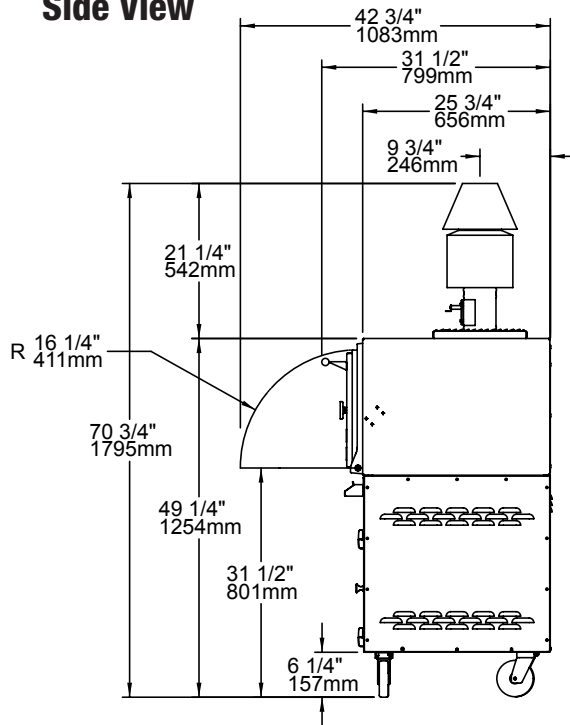

Iso View

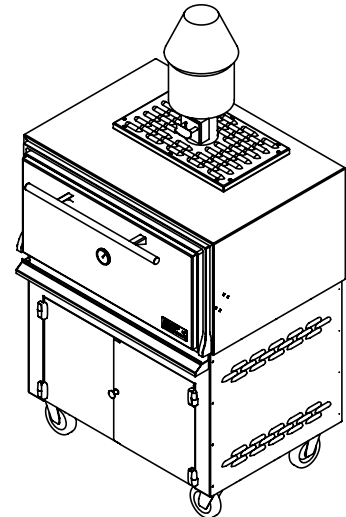

Top View

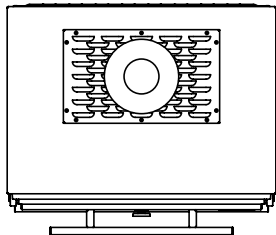

A larger model is available (WS-CBO-3738)

VENTING INFORMATION

The WS-CBO 3728 is a solid-fuel cooking appliance and must be vented using a Listed Type 1 exhaust hood, or one constructed in accordance with NFPA 96 and all relevant local and national codes. The oven must be vented as a solid fuel appliance in accordance with all relevant local and national codes, and in a manner acceptable to the authority having jurisdiction.

Unit Shipping Weight: approximately 900 lbs.



Intertek



Intertek
ANSI/NFPA STD 4



An ongoing program of product improvement may require us to change specifications without notice.
Revised October 2011

WOOD STONE CORPORATION

1801 W. Bakerview Rd.
Bellingham, WA 98226 USA

Toll Free (800) 988-8103

Tel (360) 650-1111

Fax (360) 650-1166

info@woodstone-corp.com or visit woodstone-corp.com