

Wood Stone

BARREL ROASTING OVEN

Wood-Fired Oven



Job Name	
Model	WS-BRO
Item#	
Fuel Type	Wood-Fired



The Wood Stone Barrel Roasting oven is a unique solid fuel burning unit featuring a stone-lined interior. The oven has a thick, monolithic cast-ceramic vessel and firebox that has been insulated to keep external temperatures down, while creating a "deep heat sink" of cooking energy within the chamber of the oven.

The top of the barrel shaped cooking chamber has a 25-3/4-inch opening allowing access for hanging or grilling food items. The outside of this chamber is insulated and covered with an expanded metal mesh which functions as an anchoring surface for a stucco mix.

The unit comes complete with one cooking grate and a lid. The oven sits on a heavy-duty frame for easy installation and includes a grease drain to make the removal of cooking fats easier. **Please note that a grease trap or some other collection method for this drain will need to be planned for and taken care of on-site.**

The ceramic interior is heated by a building a fire in the firebox on the front of the unit. The temperature is controlled by the addition of wood in order to meet the needs of a variety of menu options. Items can be cold smoked, hot smoked, roasted or even broiled depending on the temperature of the vessel and the cooking location. The oven is ETL Listed with a 36-inch side clearance to combustible construction.

The Wood Stone Barrel Roasting Oven must be vented using a Listed Type 1 exhaust hood or one constructed in accordance with all relevant local and national codes. The byproducts of combustion and cooking vapors exhaust through the top and around the firebox of the oven. The oven should be vented in accordance with all local and national codes, and in a manner acceptable to the authority having jurisdiction.

OPTIONAL ACCESSORIES

- Stainless Steel Oven Tools
- Wood Stone also manufactures a full line of accessories for stone hearth cooking
- Wood Handling Cart
- Ash Shovel
- Brass-Bristled Floor Brush
- Ash Dolly



Wood Stone

An ongoing program of product improvement may require us to change specifications without notice.
Revised August 2009

WOOD STONE CORPORATION
1801 W. Bakerview Rd.
Bellingham, WA 98226 USA

Toll Free (800) 988-8103
Tel (360) 650-1111
Fax (360) 650-1166

info@woodstone-corp.com or visit www.woodstone-corp.com



BARREL ROASTING OVEN

Wood-Fired Oven

Model
WS-BRO

Front View

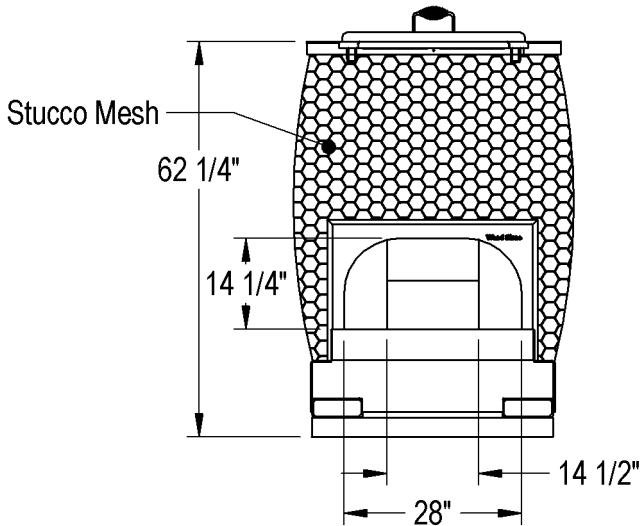

Side View

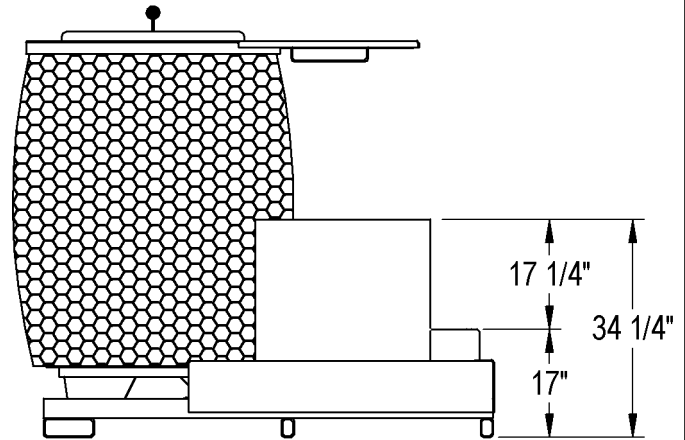

Top View

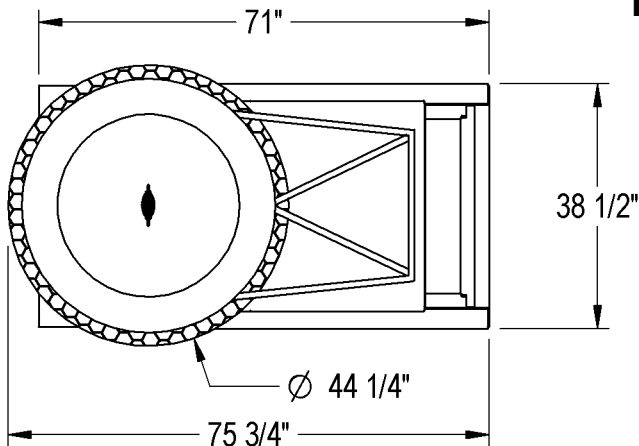

Top View (no lid)

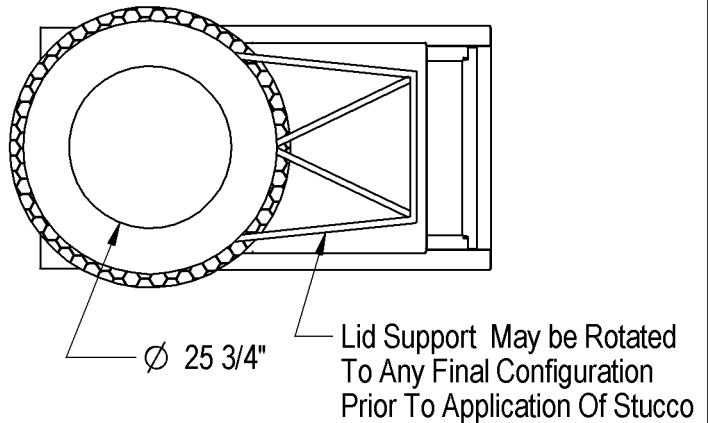

UTILITIES SPECIFICATIONS

Venting Information

The WS-BRO must be vented using a Listed Type 1 exhaust hood, or one constructed in accordance with NFPA 96 and all relevant local and national codes. The oven must be vented as a solid fuel appliance, in accordance with all relevant local and national codes, and in a manner acceptable to the authority having jurisdiction.

**Unit Shipping Weight:
3,200 lbs.**



WoodStone

An ongoing program of product improvement may require us to change specifications without notice.
Revised August 2009

WOOD STONE CORPORATION

1801 W. Bakerview Rd.
Bellingham, WA 98226 USA

Toll Free (800) 988-8103

Tel (360) 650-1111

Fax (360) 650-1166

info@woodstone-corp.com or visit www.woodstone-corp.com