



Installation and Operation Manual

CUSTOM CONFIGURATIONS

Stone Hearth Oven



DESIGNER SERIES

WS-DS-7248



Wood Stone

WOOD STONE CORPORATION
1801 W. Bakerview Rd.
Bellingham, WA 98226 USA

Toll Free (800) 988-8103
Tel (360) 650-1111
Fax (360) 650-1166

www.woodstone-corp.com
Revised February 2010

This page intentionally left blank >



TABLE OF CONTENTS

DESIGNER SERIES OVEN -----	2
SPECIFICATIONS-----	4
INSTALLATION CLEARANCES -----	5
MOVING THE OVEN -----	6
ASSEMBLY -- CONNECTIONS-----	7
GAS SPECIFICATIONS -----	8
VENTING -----	9
OPERATION -----	10
DAILY MAINTENANCE -----	11
CONTROLLER -----	12
TROUBLESHOOTING GUIDE-----	13
120 V ELECTRICAL DIAGRAM -----	14
INTERIOR LIGHT CIRCUIT -----	15
LIMITED WARRANTY -----	16



INSTALLATION AND OPERATION MANUAL FOR THE WOOD STONE DESIGNER SERIES OVEN

NATURAL GAS OR PROPANE FUELED STONE HEARTH OVEN

WS-DS-7248-RFG MODELS

ADDITIONAL COPIES AVAILABLE UPON REQUEST



**READ ALL INSTRUCTIONS BEFORE INSTALLING AND USING THE
APPLIANCE. SAVE THE INSTRUCTIONS**



INSTALLATION AND OPERATING INSTRUCTIONS FOR THE WS-DS-7248 WOOD STONE DESIGNER SERIES OVEN

DO NOT THROW THIS MANUAL AWAY

RETAIN THIS MANUAL FOR FUTURE REFERENCE

Additional copies of this manual and prompt responses to service/maintenance questions are available from Wood Stone @ 1-800-988-8103.

A MAJOR CAUSE OF OVEN-RELATED FIRES IS FAILURE TO MAINTAIN REQUIRED CLEARANCES (AIR SPACES) TO COMBUSTIBLE MATERIALS. IT IS OF UTMOST IMPORTANCE THAT THIS OVEN BE INSTALLED ONLY IN ACCORDANCE WITH THESE INSTRUCTIONS.

IMPORTANT: Consult your local gas supplier for a statement outlining a procedure to be followed in the event you smell gas. Post the statement in a prominent location.

Please read this entire manual before you install the oven. Failure to follow instructions may result in property damage, bodily injury or even death. Contact your local building or fire officials about restrictions and installation inspection in your area.

Install and use only in accordance with Wood Stone Installation and Operation Instructions

It is recommended that this oven be installed, maintained and serviced by authorized professionals.

WARNING: This product must be installed by a Licensed Plumber or Gas Fitter when installed within the Commonwealth Of Massachusetts.

Wood Stone's gas-fired Designer Series Ovens have been tested and approved by Intertek Testing Services, and are ETL Listed to ANSI Z83.11-2006 / CSA 1.8-2006 Food Service Equipment

FOR YOUR SAFETY: Do not store or use gasoline or other flammable vapors or liquids in the vicinity of this or any other appliance. Also, always keep the area under and around this appliance free and clear of any and all combustible materials.

WARNING: Improper installation, adjustment, alteration, service or maintenance can result in property damage, injury or death. Read the installation, operation and maintenance instructions thoroughly before installing or servicing this equipment.



FRONT VIEW

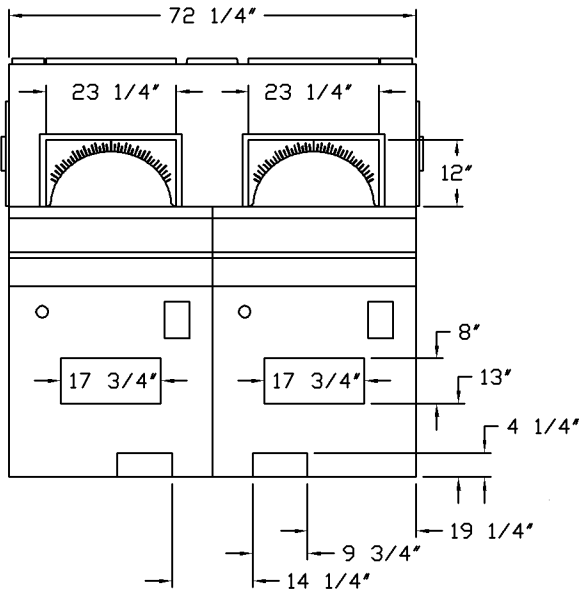

SIDE VIEW

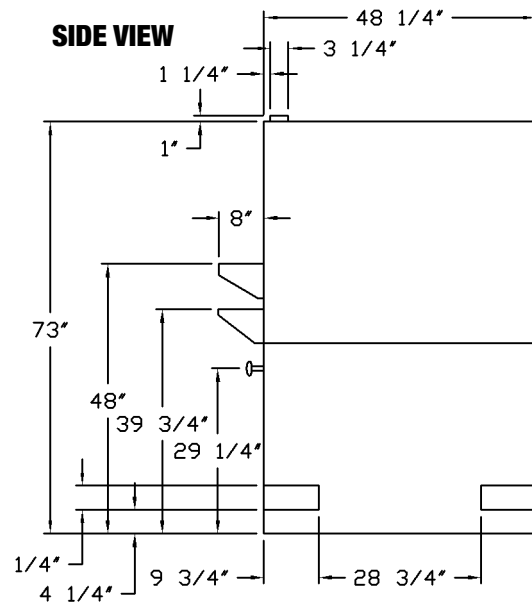

PLAN VIEW

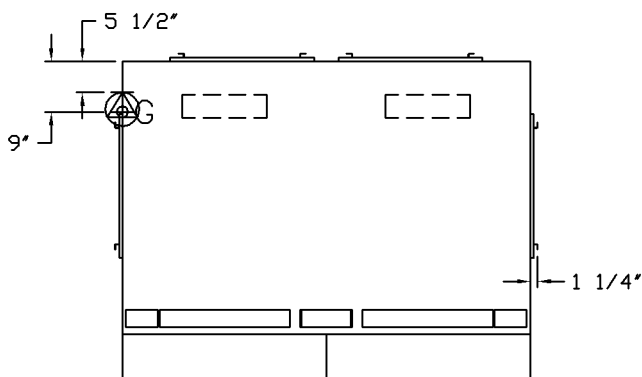

UTILITIES SPECIFICATIONS

Gas-3/4 inch gas inlet (female threaded)
 225,000 BTU Natural Gas Supply OR
 225,000 BTU Propane (LP) Supply
 Maximum gas inlet pressure-
 1/2 psi (14 inches WC)

Electrical-
 120 VAC, 2 amp 50/60 Hz
 Optional- 240 VAC, 1 amp 50/60 Hz

SHIPPING WEIGHT: 4450 LBS.



WARNING: Do Not pack required air space (clearance) with insulation or other materials. When non-combustible building materials contact the body of the oven, the clearances to combustibles are transferred to those non-combustibles.

IF THIS OVEN IS NOT PROPERLY INSTALLED A FIRE MAY RESULT. TO REDUCE THE RISK OF FIRE, FOLLOW THESE INSTALLATION INSTRUCTIONS. A MAJOR CAUSE OF OVEN RELATED FIRES IS FAILURE TO MAINTAIN REQUIRED CLEARANCES (AIR SPACES) TO COMBUSTIBLE MATERIALS. IT IS OF UTMOST IMPORTANCE THAT THIS OVEN BE INSTALLED ONLY IN ACCORDANCE WITH THESE INSTRUCTIONS.



WARNING: Installation and servicing of this product could expose you to glasswool/ceramic fibers as well as Calcium Silicate dust. **ALWAYS WEAR RESPIRATORY AND EYE PROTECTION WHEN INSTALLING OR SERVICING THIS APPLIANCE.** Please read this entire manual before you install the oven. Failure to follow instructions may result in property damage, bodily injury or even death. Contact your local building or fire officials about restrictions and installation inspection in your area.

- a. The Wood Stone Designer Series Oven must have a minimum 1-inch clearance to combustibles from all sides, 7 inch clearance to combustibles from the top. If building a facade that will contact the oven, use completely non-combustible materials. Any facade wall on the front of the oven must be of non-combustible construction. Please note that standard drywall (or sheet rock) is considered a limited combustible. Any walls perpendicular to the front of the oven in the area 30 inches to either side of the doorway and 36 inches in front of the oven should have a non-combustible surface.
- b. This oven should be installed on a non-combustible floor surface. The non-combustible floor surface must extend 36 inches in front of and 30 inches to either side of the oven doorway.
- c. If equipped, do not cover the glass viewing windows. If constructing a facade wall around the oven, provide openings for the viewing windows. Seal the openings to the oven using a non-combustible insulation and an appropriate flashing, (i.e. steel or ceramic tile). Facade materials above and 6 inches on each side of window must be non-combustible.

NOTE: DO NOT FILL REQUIRED AIR SPACE WITH INSULATION OR OTHER MATERIALS. DO NOT BLOCK AIR INTAKE AREA ON SERVICE PANELS AT FRONT OF THE OVEN. DO NOT BLOCK SERVICE PANELS. THESE MUST REMAIN REMOVABLE TO ALLOW ACCESS FOR MAINTENANCE AND SERVICE.



LIFTING THE OVEN -- 6,000 LBS. FORKLIFT REQUIRED

The Wood Stone Designer Series 7248 oven weighs approximately 4450 lbs. The oven may be moved using a forklift using the forklift pockets provided at the front and rear of the unit. The oven may also be moved using a pallet jack. If the oven is to be installed against a wall, you may need to leave access to the back of the oven to complete the utility connections.

CAUTION: These ovens are extremely heavy. If using a pallet jack to move the oven DO NOT ATTEMPT to move the oven over anything but a smooth flat surface. ATTEMPTING to move the oven with a pallet jack over anything but a smooth flat surface could cause the oven to tip over resulting in potential serious injury, damage to the oven and property damage.

NOTE: This is a general example of forklift pockets. Forklift pocket locations may vary as Designer Series ovens are custom built.

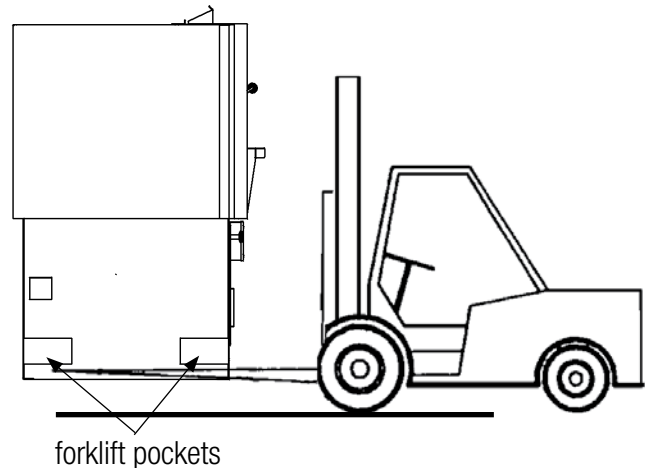

DELIVERY NOTE: The customer will receive an Oven Shipping Notification when the oven leaves the Wood Stone factory. This will include a PRO# and a trucking company contact number. Wood Stone recommends that you confirm the delivery date/time with the trucking company before committing to heavy equipment and/or labor. Our goal is a smooth and safe delivery. Thank you.



ELECTRICAL CONNECTIONS

A junction box is provided on one side of the oven (specified at time of order) towards the back of the oven. The incoming power is connected to oven at this junction box. Check the equipment data plate to verify proper voltage before connecting the oven. If needed, the location of the junction box may be easily relocated to the opposite side of the oven by the installer.

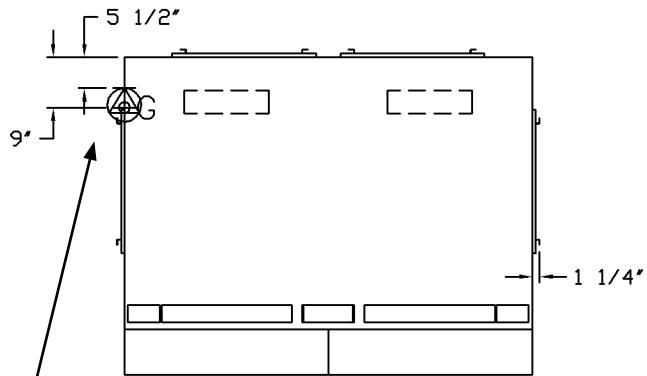

Utility locations-Left side configuration.

Connect the incoming gas supply to the 3/4 inch NPT (female) gas inlet located on one side of the oven. A gas inlet is available on each side of the oven. Both inlets are plugged at the factory. Remove the plug from the inlet to which the connection will be made. Verify that the unused inlet remains plugged. A 3/4 inch full-flow gas shut-off valve (supplied by others) must be installed on the gas supply near the oven in such a way that it is readily accessible.



This appliance must be electrically grounded in accordance with local code, or in the absence of local code, with the national electrical code, ANSI/NFPA 70, or the Canadian Electrical Code, CSA C22.2, as applicable. An electrical diagram is provided inside the oven control box, and on the transformer box beneath the oven as well, and at the end of this manual.

The installation of this appliance must conform with local codes, or in the absence of local codes, with the National Fuel Gas Code, ANSI Z223.1, the Natural Gas installation Code CAN/CGA-B149.1 or the Propane Installation Code, CAN/CGA-B149.2, as applicable including:

1. The appliance and its individual shutoff valve (supplied by others) must be disconnected from the gas supply piping system during any pressure testing of that system at test pressures in excess of 1/2 psi (3.45 kPa).
2. The appliance must be isolated from the gas supply piping system by closing its individual manual shutoff valve (supplied by others) during any pressure testing of the gas supply piping system at test pressure, equal to or less than 1/2 psi (3.45 kPa).

The incoming gas supply pressure must not exceed 1/2 psi (14 inches WC). If the incoming gas pressure exceeds 1/2 psi, an external gas regulator must be installed in the supply line. If the supply pressure is less than 1/2 psi, no external regulator is required.

The installer should bleed any air out of the gas line supplying the oven. All gas connections and fittings on the oven should be leak checked with an approved soap solution.

Checking the burner manifold pressure. The burner manifold pressure has been set at the factory, however it should be checked by the installer. The pressure should be checked at the outlet tap on the Honeywell gas valve, located on the back of the control box. Once the manometer is connected, turn the oven on and use the knob on the oven to adjust the flame to its maximum height. Then check the manifold pressure.

Natural Gas (NG) Models: Radiant Flame (Dome) burner(s) - 5" WC
Infrared (Underfloor) burner(s) - 3.5" WC

Propane (LP) Models: Radiant Flame (Dome) burner(s) - 9.5" WC
Infrared (Underfloor) burners - 9" WC

This information can also be found on the data plate located beneath the oven.



The Wood Stone Designer Series ovens must be vented using a Type 1 exhaust hood, or one constructed and installed in accordance with NFPA 96, Chapter 14 and all relevant Local and National Codes. Wood Stone offers exhaust hoods especially designed for our ovens by Gaylord Industries (see specifications below).

Designer Series ovens with model numbers containing a -W (other than the 'W' in the beginning of the model number) should be vented in accordance with codes concerning solid fuel appliances (NFPA 96, Chapter 14). Due to the dangers of creosote buildup and of sparks entering the duct, these models should be vented separately from all other kitchen equipment or in such a manner as is acceptable to the authority having jurisdiction. The Wood Stone customer support staff is available to answer any questions concerning installation and venting of the oven; call 1-800-988-8103 for assistance and technical support.

Solid fuel exhaust contains creosote and other substances that accumulate in ducting, creating a risk of fire. The rate of accumulation will vary with respect to flue gas temperature, wood type and moisture content. Frequent, regularly scheduled, thorough flue cleaning is the best way to minimize the risk of flue fires.

CREOSOTE - AND THE NEED FOR ITS REMOVAL

When wood is burned slowly, it produces tar and other organic vapors, which combine with expelled moisture to form creosote. The creosote vapors condense in the relatively cool oven flue of a slow-burning fire. As a result, creosote residue accumulates in the duct. When ignited, this creosote makes an extremely hot fire. The duct serving this oven should be inspected at least twice a month during the first two months of operation, to establish rate of creosote buildup and necessary cleaning schedule. If creosote or soot has accumulated, it should be removed to reduce the risk of a flue fire. The interior floor and dome of the oven do not require creosote or soot removal. The oven flue and exhaust system will require inspection and cleaning. The exhaust system should be inspected and cleaned per the manufacturer's and or local code official's recommendations.

FOR OVENS NOT EQUIPPED WITH A ROUND FLUE COLLAR: The cooking equipment is to be provided with an exhaust hood tested for compliance with the Standard for Ventilation Control and Fire Protection of Commercial Cooking Operations (NFPA 96, Chapter 14).

WOOD STONE RECOMMENDS THAT THE OPERATOR REFER TO THE EXHAUST HOOD MANUFACTURER'S RECOMMENDATIONS FOR INSPECTION, MAINTENANCE AND CLEANING. WOOD STONE RECOMMENDS THAT YOU SUBMIT YOUR VENTING PLANS TO THE AUTHORITY HAVING JURISDICTION BEFORE PROCEEDING WITH INSTALLATION OF ANY GAS AND/OR SOLID FUEL BURNING APPLIANCE.



DO NOT OVER-FIRE -- WHEN FLAMES SPILL OUT OF THE DOOR OR IF THE OVEN FLOOR TEMPERATURE EXCEEDS 750 DEGREES F, YOU ARE OVER FIRING THE OVEN.

INITIAL OVEN STARTUP

FIRST DAY

1. Make sure main gas supply is on (valve parallel with gas line).
2. Push I/O button on the oven controller(s), there may be more than one controller depending on how your oven is configured. If equipped use the arrows on the controller to adjust the underfloor burner setpoint to 200 degrees F. It may take a while for the gas to purge all the air from the gas lines.
3. Once the burner ignites, make sure the flame is at its lowest setting and allow the oven to operate at this setting for about 1 hour.
4. After 4 hours, raise radiant flame to 25% (~ 5-inch flame), hold this setting for 4 hours.
5. After 4 hours at 25% flame, raise to 50% flame and hold for another 4 hours.
The oven can be left at this setting all night.

SECOND DAY

1. Turn the radiant flame(s) to 75% height until the desired cooking temperature is achieved.

GENERAL DAILY OVEN OPERATION

The oven deck temperature is displayed on the controller readout.

END OF THE DAY

Push I/O button on the oven controller, all gas will go off, even the pilot. There may be a separate controller for each cooking section of the oven, depending upon the configuration of the oven.

BEGINNING OF THE DAY

Push I/O button and turn the radiant flame to its highest setting. If equipped, adjust the underfloor burner setpoint to your desired cooking temperature. Oven should reach the desired cooking temperature within two hours. Use the flame height knob to control the amount of heat in the oven.

NEVER PLACE ANYTHING IN OR ABOVE THE RADIANT FLAME



OVEN INTERIOR

Wood Stone recommends the use of a brass bristled brush for sweeping aside excess food particles that will accumulate on the floor of the oven during use. The oven floor can be cleaned with a damp rag. **DO NOT USE ICE OR EXCESSIVE WATER ON THE FLOOR; THIS IS TO PREVENT THERMAL SHOCKING OF THE STONE.**

There is a stainless steel burner guard to prevent food from falling on and thereby obstructing the gas orifices of the radiant flame. If food gets into the radiant flame well and the flame is visibly obstructed, turn the oven off immediately, and call for service.

DO NOT USE THE RADIANT BURNER WELL AS A DUMP FOR DEBRIS OR TRASH INCINERATION; MAKE EVERY ATTEMPT TO KEEP DEBRIS FROM DROPPING INTO THE WELL.

OVEN EXTERIOR

All painted and stainless steel surfaces should be cleaned as necessary using an approved mild detergent, hot water and a soft cloth or sponge. Stubborn residues may be removed using a nonmetallic scouring pad. When scouring stainless steel surfaces, scrub with the grain of the metal to prevent scratching. Do not use any type of scouring pad on glass surfaces.

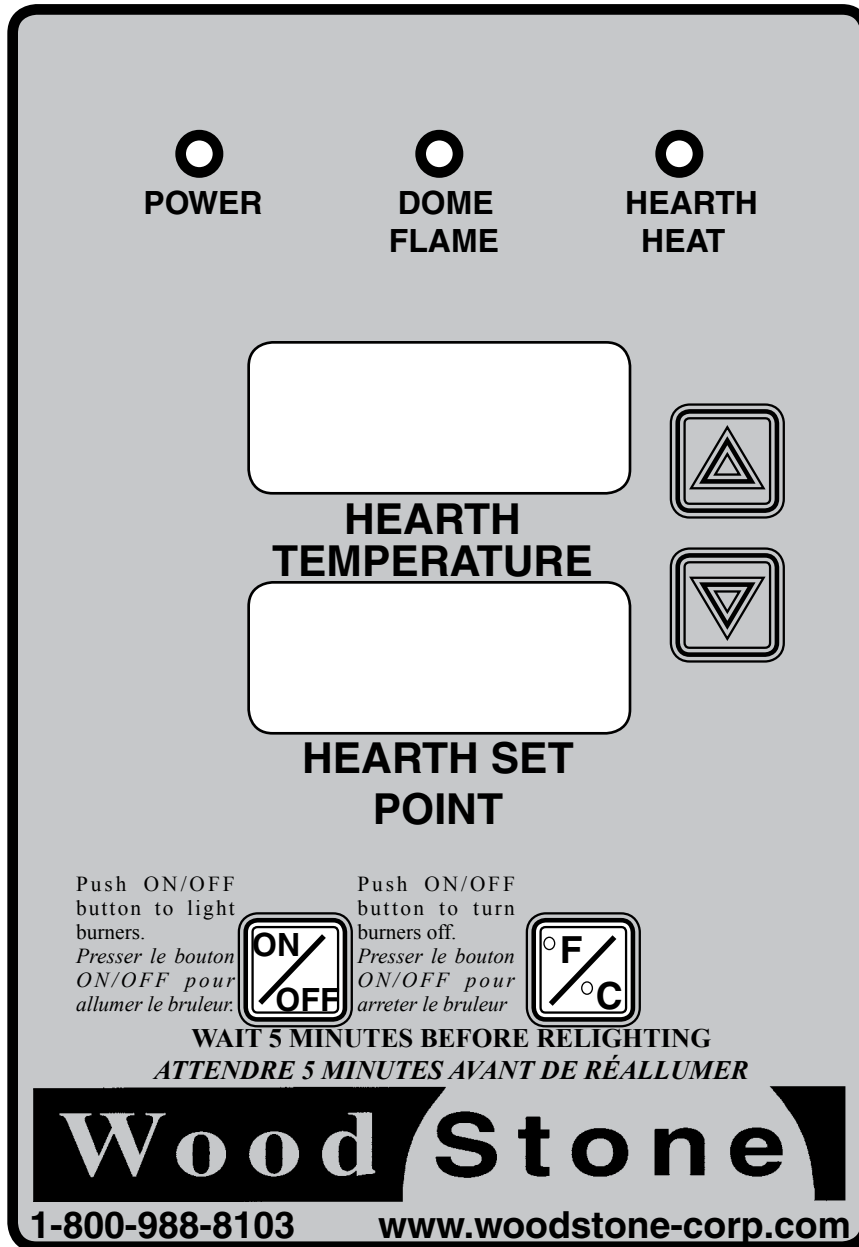



PROBLEM	CAUSE/SOLUTION
Controller will not turn on	<ol style="list-style-type: none"> 1. Incoming power to oven turned off. Check circuit breaker for circuit supplying the oven. Check that any wall switches external to the oven that control oven power are turned on. Check that any interlocks external to the oven are turned on. 2. If control still does not turn on, please contact Wood Stone for assistance.
Flame does not light	<ol style="list-style-type: none"> 1. Is gas turned on to the oven? Is gas shut-off valve turned all the way on? 2. Debris in burner. Burner may require cleaning. Contact Wood Stone for assistance. 3. Damaged igniter or gas valve. Contact Wood Stone for assistance. If the oven is being started for the first time: <ul style="list-style-type: none"> • Has all air been bled from the gas line? • Are the switches on the Honeywell gas valves in the 'ON' position? <p>Note: (Valves are located on the back of the control box, beneath the oven.)</p>
Flame cuts out	<ol style="list-style-type: none"> 1. Debris in burner. 2. Oven is being run with the night door in place. Night door must be removed whenever the oven is turned on. 3. Wind blowing into the oven, or other venting issues.
Display reads 'OPEN'	<ol style="list-style-type: none"> 1. Thermocouple is not plugged into control box. 2. Damaged thermocouple - call Wood Stone.

Please contact Wood Stone at 1-800-988-8103 should service be necessary, or if you have any questions about your oven. Our office hours are 8am to 4:30pm Pacific Standard Time. Follow the recorded instructions for Emergency Service if you require assistance during non-business hours. A Wood Stone technician will promptly respond to your call.



RFG-IR 120 VAC MODELS

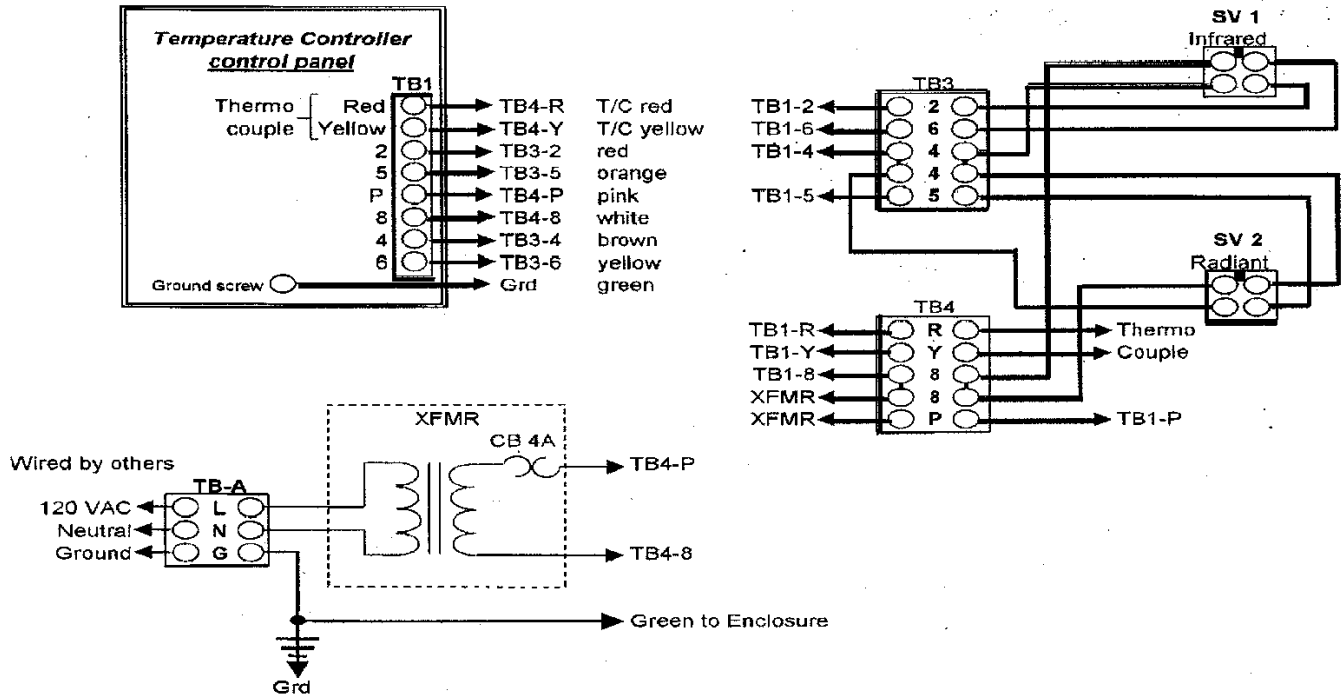



INTERIOR LIGHT CIRCUIT

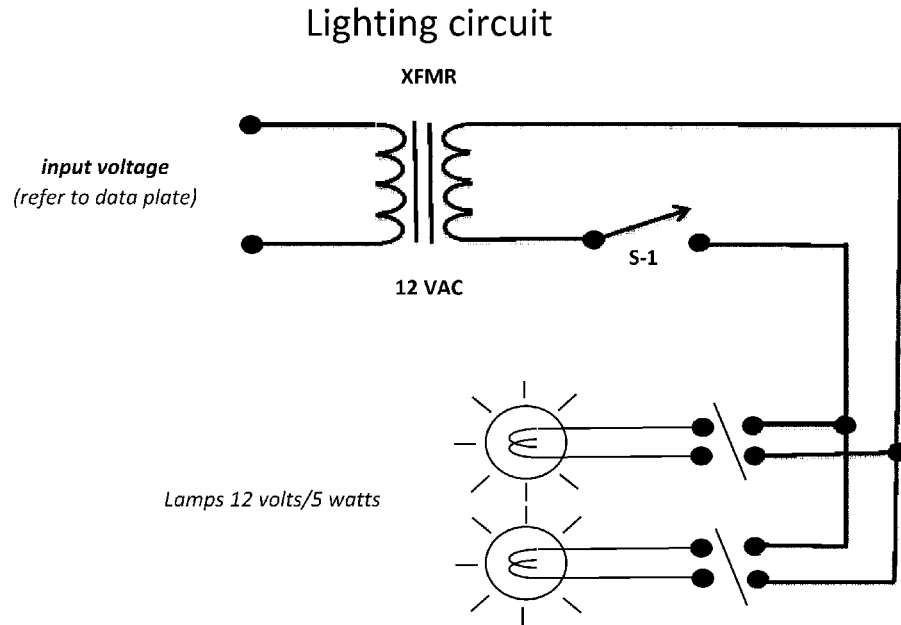



ALL WARRANTY SERVICE MUST BE PRE-APPROVED BY WOOD STONE PLEASE CONTACT THE FACTORY FIRST

Please call 1-800-988-8103 or 1-360-650-1111 seven days a week. Our normal business hours are 8am to 4:30pm Pacific Standard time Monday through Friday. If calling during non-business hours, follow the recorded instructions for emergency service and a Wood Stone technician will get back to you promptly. Wood Stone warrants its equipment to the original purchaser against defects in material or manufacture for a period of one year from the original date of purchase subject to the following exclusions and limitations.

EXCLUSIONS

The warranties provided by Wood Stone do not apply in the following instances:

1. In the event that the equipment is improperly installed. Proper installation is the responsibility of the installer; proper installation procedures are prescribed by the Wood Stone installation manual.
2. In the event the equipment is improperly maintained. Proper maintenance is the responsibility of the user; proper maintenance procedures are prescribed in the Wood Stone installation manual.
3. In the event that the failure or malfunction of the appliance or any part thereof is caused by abnormal use or is otherwise not attributable to defect in material or manufacture.
4. In the event that the appliance, by whatever cause, has been materially altered from the condition in which it left the factory.
5. In the event that the rating plate has been removed, altered or obliterated.
6. On parts that would be normally worn or replaced under normal conditions.
7. Normal cracking due to expansion and contraction stress relief in either the dome or oven deck.
- 8. In the event that pressed log products of any type have been burned in the equipment.**

If any oral statements have been made regarding this appliance, such statements do not constitute warranties and are not part of the contract of sale. This Limited Warranty constitutes the complete, final and exclusive statement with regard to warranties.

THIS LIMITED WARRANTY IS EXCLUSIVE AND IN LIEU OF ALL OTHER WARRANTIES WHETHER WRITTEN, ORAL OR IMPLIED, INCLUDING, BUT NOT LIMITED TO, ANY WARRANTY OF MERCHANTABILITY OR FITNESS FOR PARTICULAR PURPOSE OR WARRANTY AGAINST LATENT DEFECTS

LIMITATIONS OF LIABILITY:

In the event of warranty claim or otherwise, the sole obligation of Wood Stone shall be the repair and/or replacement, at the option of Wood Stone, of the appliance or component or part thereof. Such repair or replacement shall be at the expense of Wood Stone with the exception of travel over 100 miles or two hours, overtime, and holiday charges which shall be at the expense of the purchaser. Any repair or replacement under this warranty does not constitute an extension of the original warranty for any period of the appliance or for any component or part thereof. Parts to be replaced under this warranty will be repaired or replaced at the option of Wood Stone with new or functionally operative parts. The liability of Wood Stone on any claim of any kind, including claims based on warranty, expressed or implied, contract, negligence, strict liability or any other theories shall be solely and exclusively the repair or replacement of the product as stated herein, and such liability shall not include, and purchaser specifically renounces any rights to recover, special, incidental, consequential or other damages of any kind whatsoever, including, but not limited to, injuries to persons or damage to property, loss of profits or anticipated profits, or loss of use of the product.

TO SECURE WARRANTY SERVICE:

If you claim a defect covered by this Limited Warranty, direct your claim to:
Wood Stone Corporation 1801 W. Bakerview Rd. Bellingham, WA 98226 USA Attn: National Service Manager